

HOTDISPAY

Document Title	GWX3 R0 Tentative Product Specification			Page No.	1/25
Document No.		Issue date	2022/11/08	Revision	00

Tentative Product Specification

To:

Product Name: H150GWX3 R0

Document Issue Date: 2022/11/08

Customer
<u>SIGNATURE</u>

Please return 1 copy for your confirmation with your signature and comments.

<u>SIGNATURE</u>
REVIEWED BY CQM

PREPARED BY FAE

- Note :
1. Please contact InfoVision Company before designing your product based on this product.
 2. The information contained herein is presented merely to indicate the characteristics and performance of our products. No responsibility is assumed by IVO for any intellectual property claims or other problems that may result from application based on the module described herein.

FQ-7-30-0-009-03D

HOTDISPAY

Document Title	H150GWX3 R0 Tentative Product Specification			Page No.	2/25
Document No.		Issue date	2022/11/08	Revision	00

Revision	Date	Page	Revised Content/Summary	Remark
00	2022/11/08	--	First issued.	-

HOTDISPAY

Document Title	H150GWX3 R0 Tentative Product Specification			Page No.	3/25
Document No.		Issue date	2022/11/08	Revision	00

CONTENTS

1.0 GENERAL DESCRIPTIONS	4
2.0 ABSOLUTE MAXIMUM RATINGS	6
3.0 OPTICAL CHARACTERISTICS.....	7
4.0 ELECTRICAL CHARACTERISTICS.....	10
5.0 MECHANICAL CHARACTERISTICS.....	18
6.0 RELIABILITY CONDITIONS	21
7.0 PACKAGE SPECIFICATION	22
8.0 LOT MARK	23
9.0 GENERAL PRECAUTION	24

HOTDISPAY

Document Title	H150GWX3 R0 Tentative Product Specification			Page No.	4/25
Document No.		Issue date	2022/11/08	Revision	00

1.0 General Descriptions

1.1 Introduction

The H150GWX3 R0 is a Color Active Matrix Liquid Crystal Display with a back light system. The matrix uses a-Si Thin Film Transistor as a switching device. This TFT LCD has a 15 inch diagonally measured active display area with XGA resolution (1,024 horizontal by 768 vertical pixels array).

1.2 Features

- Supported XGA Resolution
- LVDS Interface
- Compatible with RoHS Standard

1.3 Product Summary

Items	Specifications	Unit
Screen Diagonal	15.0	inch
Active Area (H x V)	304.13 x 228.10	mm
Number of Pixels (H x V)	1,024 x 768	-
Pixel Pitch (H x V)	0.2970 x 0.2970	mm
Pixel Arrangement	R.G.B. Vertical Stripe	-
Display Mode	Normally Black	-
White Luminance	400 (Typ.)	cd /m ²
Contrast Ratio	800 (Typ.)	-
Response Time	25 (Max.)	ms
Input Voltage	3.3 (Typ.)	V
Power Consumption	14.487 (Max.) @ White pattern,FV=60Hz	W
Weight	1,165 (Max.)	g
Outline Dimension (H x V x D)	326.50 (Typ.) x 253.50(Typ.) x 12.50 (Max.)	mm
Electrical Interface (Logic)	LVDS	-
Support Color	16.7 M	-
NTSC	70 (Typ.)	%
Viewing Direction	All	-
Surface Treatment	AG+3H	-

HOTDISPAY

Document Title	H150GWX3 R0 Tentative Product Specification			Page No.	5/25
Document No.		Issue date	2022/11/08	Revision	00

1.4 Functional Block Diagram

Figure 1 shows the functional block diagram of the LCD module.

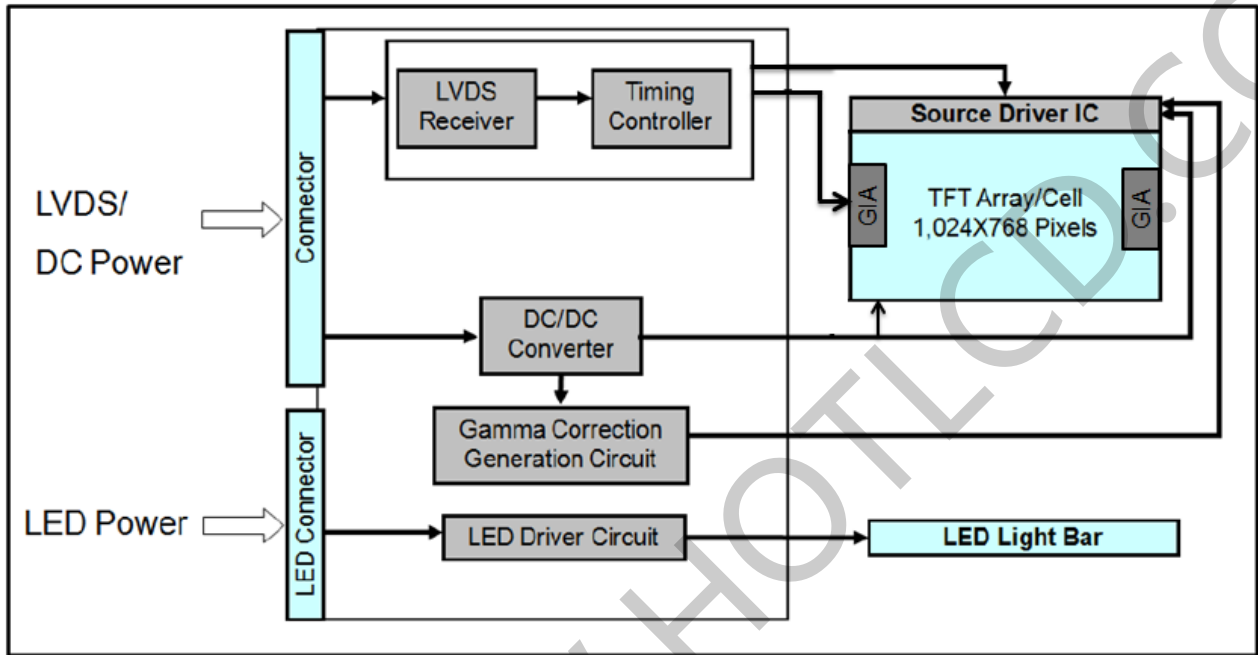

Figure 1 Block Diagram

1.5 Pixel Mapping

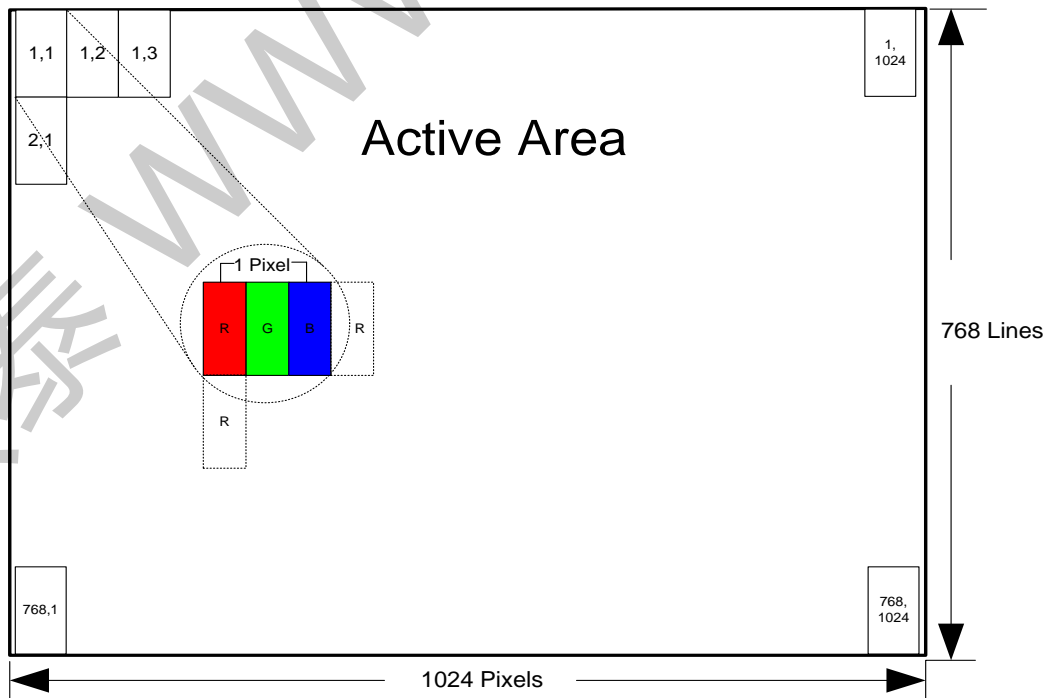

Figure 2 Pixel Mapping

HOTDISPAY

Document Title	H150GWX3 R0 Tentative Product Specification			Page No.	6/25
Document No.		Issue date	2022/11/08	Revision	00

2.0 Absolute Maximum Ratings

Table 1 Electrical & Environment Absolute Rating

Item	Symbol	Min.	Max.	Unit	Note
Logic Supply Voltage	V_{CC}	-0.3	3.6	V	(1),(2),(3),(4)
Operating Temperature	T_{gs}	-20	70	°C	
Storage Temperature	T_a	-30	80	°C	

Note (1) All the parameters specified in the table are absolute maximum rating values that may cause faulty operation or unrecoverable damage, if exceeded. It is recommended to follow the typical value.

Note (2) All the contents of electro-optical specifications and display fineness are guaranteed under Normal Conditions. All the display fineness should be inspected under normal conditions. Normal conditions are defined as follow: Temperature: 25°C, Humidity: 55± 10%RH.

Note (3) Unpredictable results may occur when it was used in extreme conditions. T_a = Ambient Temperature, T_{gs} = Glass Surface Temperature. All the display fineness should be inspected under normal conditions.

Note (4) Temperature and relative humidity range are shown in the figure below. Wet bulb temperature should be lower than 47°C, and no condensation of water. Besides, protect the module from static electricity.

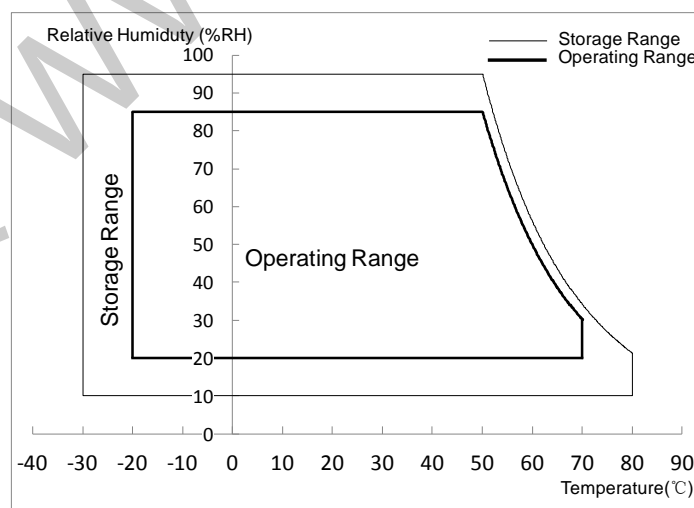

Figure 3 Absolute Ratings of Environment of the LCD Module

HOTDISPAY

Document Title	H150GWX3 R0 Tentative Product Specification	Page No.	7/25
Document No.	Issue date	2022/11/08	Revision
			00

3.0 Optical Characteristics

The optical characteristics are measured under stable conditions as following notes.

Table 2 Optical Characteristics

Item	Conditions	Min.	Typ.	Max.	Unit	Note
Viewing Angle (CR≥10)	Horizontal	θ_{x+}	80	85	-	degree (1),(2),(3),(4),(8)
		θ_{x-}	80	85	-	
	Vertical	θ_{y+}	80	85	-	
		θ_{y-}	80	85	-	
Contrast Ratio	Center	450	800	-	-	(1),(2),(4),(8) $\theta_x=\theta_y=0^\circ$
Response Time	Rising + Falling	-	-	25	ms	(1),(2),(5),(8) $\theta_x=\theta_y=0^\circ$
Color Chromaticity (CIE1931)	Red x	Typ. -0.03	0.636	Typ. +0.03	-	(1),(2),(3),(8) $\theta_x=\theta_y=0^\circ$
	Red y		0.346		-	
	Green x		0.322		-	
	Green y		0.622		-	
	Blue x		0.153		-	
	Blue y		0.063		-	
	White x		Typ. 0.313		Typ. -	
	White y		-0.05 0.329		Typ. +0.05	
NTSC	-	65	70	-	%	(1),(2),(3),(8) $\theta_x=\theta_y=0^\circ$
White Luminance	Center	340	400	-	cd/m ²	(1),(2),(6),(8) $\theta_x=\theta_y=0^\circ$
Luminance Uniformity	9 Points	75	80	-	%	(1),(2),(7),(8) $\theta_x=\theta_y=0^\circ$

Note (1) Measurement Setup:

The LCD module should be stabilized at given temperature(25℃) for 30 minutes to avoid abrupt temperature changing during measuring. In order to stabilize the luminance, the measurement should be executed after lighting backlight for 30 minutes in a windless room.

HOTDISPAY

Document Title	H150GWX3 R0 Tentative Product Specification			Page No.	8/25
Document No.		Issue date	2022/11/08	Revision	00

Figure 4 Measurement Setup

Note (2) The LED input parameter setting as:

VLED: 12V

PWM_LED: Duty 100 %

Note (3) Definition of Viewing Angle

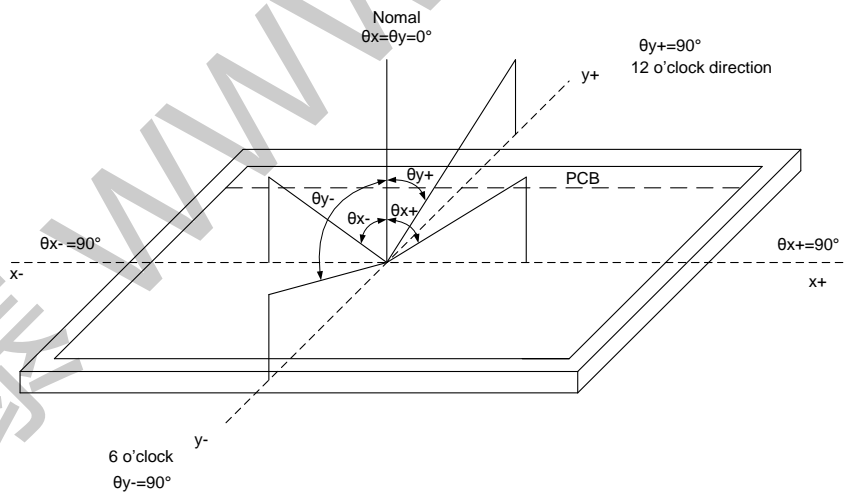

Figure 5 Definition of Viewing Angle

Note (4) Definition of Contrast Ratio (CR)

The contrast ratio can be calculated by the following expression:

Contrast Ratio (CR) = The luminance of White pattern/ The luminance of Black pattern

Note (5) Definition of Response Time (T_R , T_F)

HOTDISPAY

Document Title	H150GWX3 R0 Tentative Product Specification			Page No.	9/25
Document No.		Issue date	2022/11/08	Revision	00

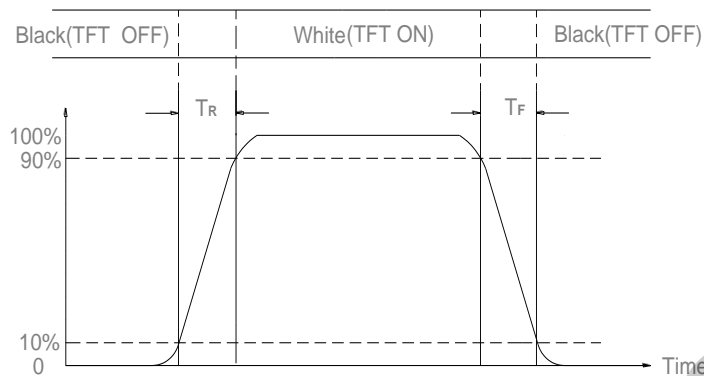

Figure 6 Definition of Response Time

Note (6) Definition of Luminance of White

Measure the luminance of White pattern (Ref.: Active Area)

Display Luminance=L1 (center point)

H—Active Area Width, V—Active Area Height, L—Luminance

Note (7) Definition of Luminance Uniformity (Ref.: Active Area)

Measure the luminance of White pattern at 9 points.

Luminance Uniformity= $\text{Min.}(L1, L2, \dots LX) / \text{Max.}(L1, L2, \dots LX)$

H—Active Area Width, V—Active Area Height, L—Luminance

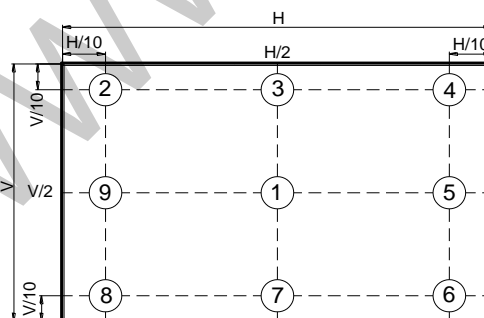

Figure 7 Measurement Locations of 9 Points

Note (8) All optical data are based on IVO given system & nominal parameter & testing machine in this document.

HOTDISPAY

Document Title	H150GWX3 R0 Tentative Product Specification			Page No.	10/25
Document No.		Issue date	2022/11/08	Revision	00

4.0 Electrical Characteristics

4.1 Interface Connector

Table 3 Signal Connector Type

Item	Description
Manufacturer / Type	STM/MSB240420HD

Table 4 Signal Connector Pin Assignment

Pin No.	Symbol	Description	Remarks
1	VCC	Power Supply 3.3V(Typ)	-
2	VCC	Power Supply 3.3V(Typ)	-
3	SDA	Only as I2C-Compatible Serial-Data Input for IVO use , Floating is recommended in the Customer	-
4	SCL	Only as I2C-Compatible Serial-Clock Input for IVO use , Floating is recommended in the Customer	-
5	Rin1-	LVDS differential data input(Rin1-)	-
6	Rin1+	LVDS differential data input(Rin1+)	-
7	VSS	Ground	-
8	Rin2-	LVDS differential data input(Rin2-)	-
9	Rin2+	LVDS differential data input(Rin2+)	-
10	VSS	Ground	-
11	Rin3-	LVDS differential data input(Rin3-)	-
12	Rin3+	LVDS differential data input(Rin3+)	-
13	VSS	Ground	-
14	CLKIN-	LVDS differential clock input(Rin3-)	-
15	CLKIN+	LVDS differential clock input(Rin3+)	-
16	VSS	Ground	-
17	Rin4-	LVDS differential data input(Rin4-)	-
18	Rin4+	LVDS differential data input(Rin4+)	-
19	VSS	Ground	-
20	BIST	LCD Panel Self Test Enable(3.3V Typ), When it is not used, Connecting to GND is recommended	(1)

Note(1): When it is used, Connecting to 3.3V and keeping LVDS signals disconnecting is recommended

HOTDISPAY

Document Title	H150GWX3 R0 Tentative Product Specification			Page No.	11/25
Document No.		Issue date	2022/11/08	Revision	00

Table 5 LED Connector Name / Designation

Item	Description
Manufacturer / Type	STM / MSB24038P5A

Table 6 LED Connector Pin Assignment

Pin No.	Symbol	Description	Remarks
1	VLED	Power Supply(12V Typ)	-
2	GND	Ground	-
3	EN	LED Backlight control on/off control(5V Typ)	-
4	PWM	System PWM Signal Input for Diming(5V Typ)	-
5	NC	NC Reserved	-

HOTDISPAY

Document Title	H150GWX3 R0 Tentative Product Specification			Page No.	12/25
Document No.		Issue date	2022/11/08	Revision	00

4.2 Signal Electrical Characteristics

4.2.1 Signal Electrical Characteristics For LVDS Receiver

The built-in LVDS receiver is compatible with (ANSI/TIA/TIA-644) standard.

Table 7 LVDS Receiver Electrical Characteristics

Parameter	Symbol	Min.	Typ.	Max.	Unit	Conditions
Differential Input High Threshold	V_{th}	-	-	+100	mV	$V_{CM}=1.2V$
Differential Input Low Threshold	V_{tl}	-100	-	-	mV	$V_{CM}=1.2V$
Magnitude Differential Input Voltage	$ V_{ID} $	150	-	600	mV	-
Common Mode Voltage	V_{CM}	-	1.2	-	V	-
Input Leakage Current	/	-10	-	10	uA	-

Note (1) Input signals shall be low or Hi- resistance state when VCC is off.

Note (2) All electrical characteristics for LVDS signal are defined and shall be measured at the interface connector of LCD.

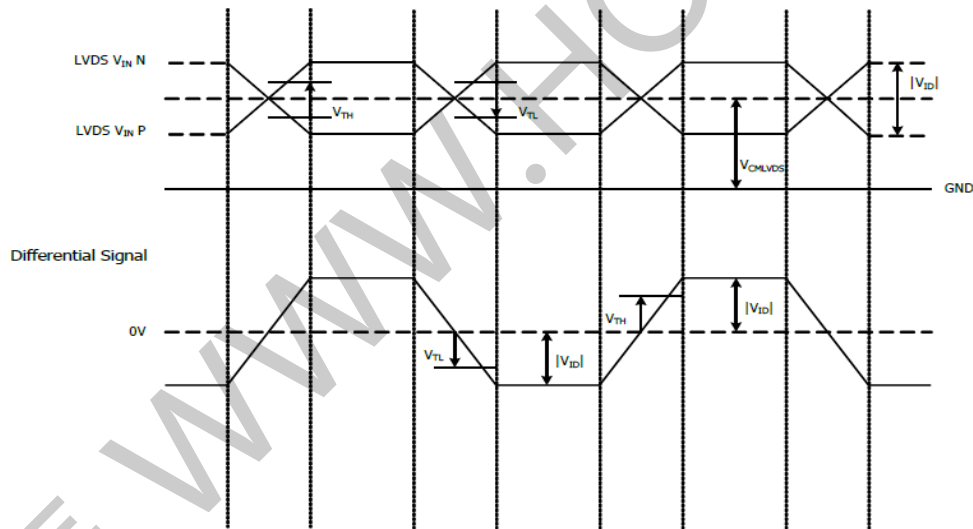

Figure 8 Voltage Definitions

Table 8 LVDS AC Electrical Characteristics

Parameter	Symbol	Min.	Typ.	Max.	Unit
Clock Period	TLVCP	-	T	-	ns
Clock High Time	TLVCH	-	4T/7	-	ns
Clock Low Time	TLVCL	-	3T/7	-	ns

Note: $T=1/F_{clk}$

HOTDISPAY

Document Title	H150GWX3 R0 Tentative Product Specification			Page No.	13/25
Document No.		Issue date	2022/11/08	Revision	00

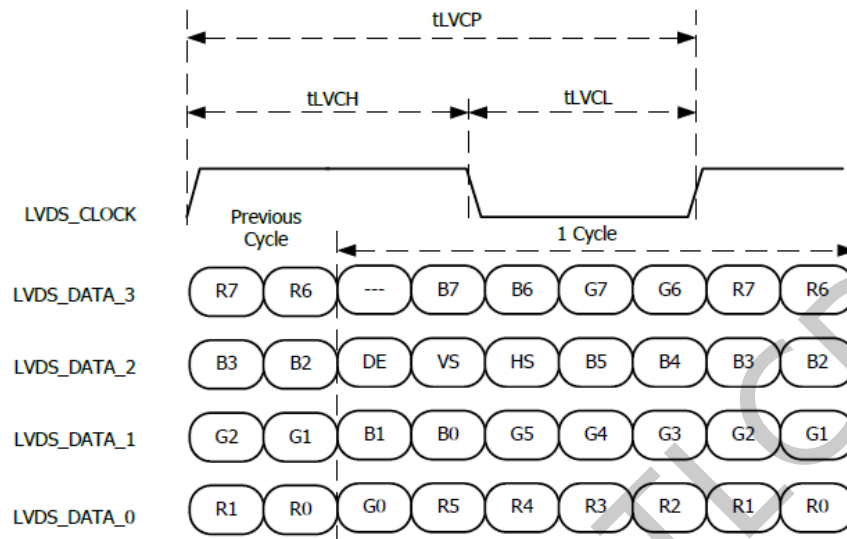

Figure 9 Data Mapping

4.2.2 LVDS Receiver Internal Circuit

Figure 10 shows the internal block diagram of the LVDS receiver. This LCD module equips termination resistors for LVDS link.

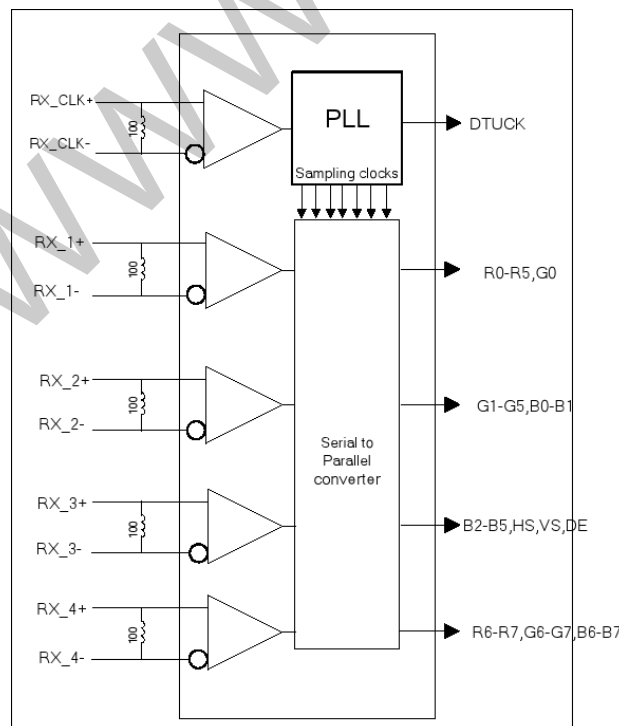

Figure 10 LVDS Receiver Internal Circuit

HOTDISPAY

Document Title	H150GWX3 R0 Tentative Product Specification			Page No.	14/25
Document No.		Issue date	2022/11/08	Revision	00

4.3 Interface Timings

Table 9 Interface Timings

Parameter	Symbol	Min.	Typ.	Max.	Unit
LVDS Clock Frequency	Fclk	50	65	80	MHz
H Total Time	HT	1224	1,344	1720	Clocks
H Active Time	HA	1,024			
V Total Time	VT	783	806	968	Lines
V Active Time	VA	768			
Frame Rate	FV	55	60	65	Hz

Note (1) Synchronization Method: DE only

Note (2) H Blank area and V Blank area can not be changed at every frame.

HOTDISPAY

Document Title	H150GWX3 R0 Tentative Product Specification			Page No.	15/25
Document No.		Issue date	2022/11/08	Revision	00

4.4 Input Power Specifications

Input power specifications are as follows.

Table 10 Input Power Specifications

Parameter	Symbol	Min.	Typ.	Max.	Unit	Note	
System Power Supply							
LCD Drive Voltage (Logic)	V_{CC}	3.0	3.3	3.6	V	(1), (2)	
VCC Current	Black Pattern	I_{CC}	-	-	0.394	A	(1),(2),(3)
	White Pattern	I_{CC}	-	-	0.511	A	
VCC Power Consumption	Black Pattern	P_{CC}	-	-	1.3	W	
	White Pattern	P_{CC}	-	-	1.687	W	
Rush Current	I_{Rush}	-	-	1.5	A	(1), (4)	
Allowable Logic/LCD Drive Ripple Voltage	V_{VCC-RP}	-	-	200	mV	(1)	
LED Power Supply							
LED Input Voltage	V_{LED}	10.8	12	12.6	V	(1),(2)	
LED Power Consumption	P_{LED}	-	-	12.8	W	(1),(5)	
PWM Signal Voltage	High	V_{PWM}	3	5	5.3	V	(1),(2)
	Low		-	-	0.5		
LED Enable Voltage	High	V_{LED_EN}	3	5	5.5	V	
	Low		-	-	0.5		
Input PWM Frequency	F_{PWM}	200	-	20K	Hz	(1),(6),(7) Ddim ≥ 5%	
LED Life Time	LT	30,000	50,000	-	Hours	(1),(8)	

Note (1) All of the specifications are guaranteed under normal conditions. Normal conditions are defined as follow: Temperature: 25°C, Humidity: 55± 10%RH.

Note (2) All of the absolute maximum ratings specified in the table, if exceeded, may cause faulty operation or unrecoverable damage. It is recommended to follow the typical value.

Note (3) The specified V_{CC} current and power consumption are measured under the $V_{CC} = 3.3$ V, $F_V = 60$ Hz condition and Black Pattern.

Note (4) The figures below is the measuring condition of V_{CC} . Rush current can be measured when T_{RUSH} is 0.5 ms.

HOTDISPAY

Document Title	H150GWX3 R0 Tentative Product Specification			Page No.	16/25
Document No.		Issue date	2022/11/08	Revision	00

V_{CC}

Figure 11 V_{CC} Rising Time

Note (5) The power consumption of LED Driver are under the $V_{LED} = 12.0V$, Dimming of Max luminance.

Note (6) Although acceptable range as defined, the dimming ratio is not effective at all conditions. The PWM frequency should be fixed and stable for more consistent luminance control at any specific level desired.

Note (7) The operation of LED Driver below minimum dimming ratio may cause flickering or reliability issue.

Note (8) The life time is determined as the sum of the lighting time till the luminance of LCD at the typical LED current reducing to 50% of the minimum value under normal operating condition.

LED Life Time Typ.50,000 Hours is for reference.

HOTDISPAY

Document Title	H150GWX3 R0 Tentative Product Specification			Page No.	17/25
Document No.		Issue date	2022/11/08	Revision	00

4.5 Power ON/OFF Sequence

Interface signals are also shown in the chart. Signals from any system shall be Hi- resistance state or low level when Vcc voltage is off.

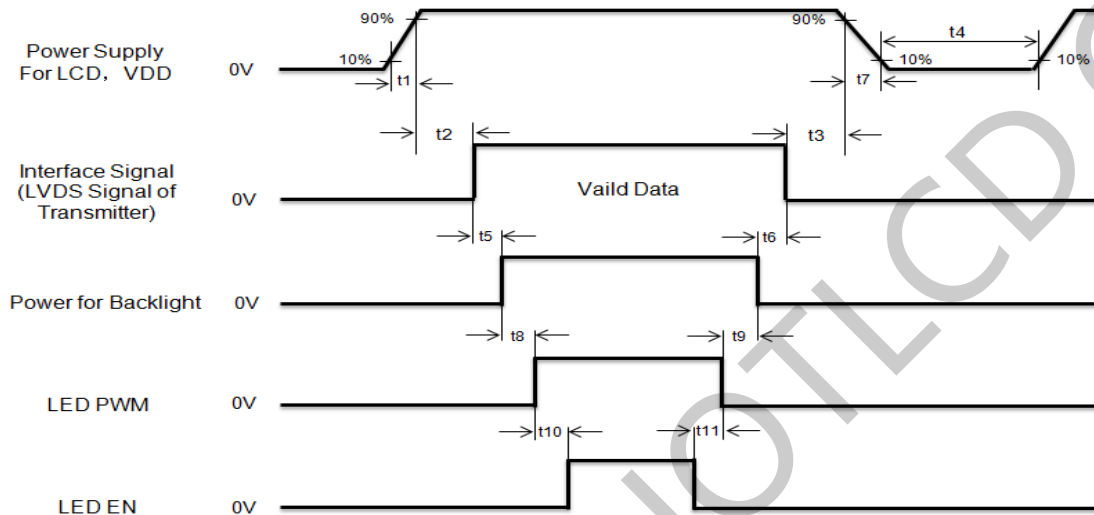

Figure 12 Power Sequence

Table 11 Power Sequencing Requirements

Parameter	Symbol	Min.	Typ.	Max.	Unit
VCC Rise Time	T1	0.5	-	10	ms
VCC Good to Signal Valid	T2	0	-	50	ms
Signal Disable to Power Down	T3	0	-	1,000	ms
Power Off	T4	1,000	-	-	ms
Signal Valid to VLED On	T5	300	-	-	ms
VLED Off to Signal Disable	T6	200	-	-	ms
VCC Fall Time	T7	0.5	-	10	ms
VLED On to LED PWM On	T8	10	-	-	ms
LED PWM Off to VLED Off	T9	10	-	-	ms
LED PWM On LED EN On	T10	10	-	-	ms
LED EN Off to LED PWM Off	T11	10	-	-	ms

HOTDISPAY

Document Title	H150GWX3 R0 Tentative Product Specification			Page No.	18/25
Document No.		Issue date	2022/11/08	Revision	00

5.0 Mechanical Characteristics

5.1 Outline Drawing

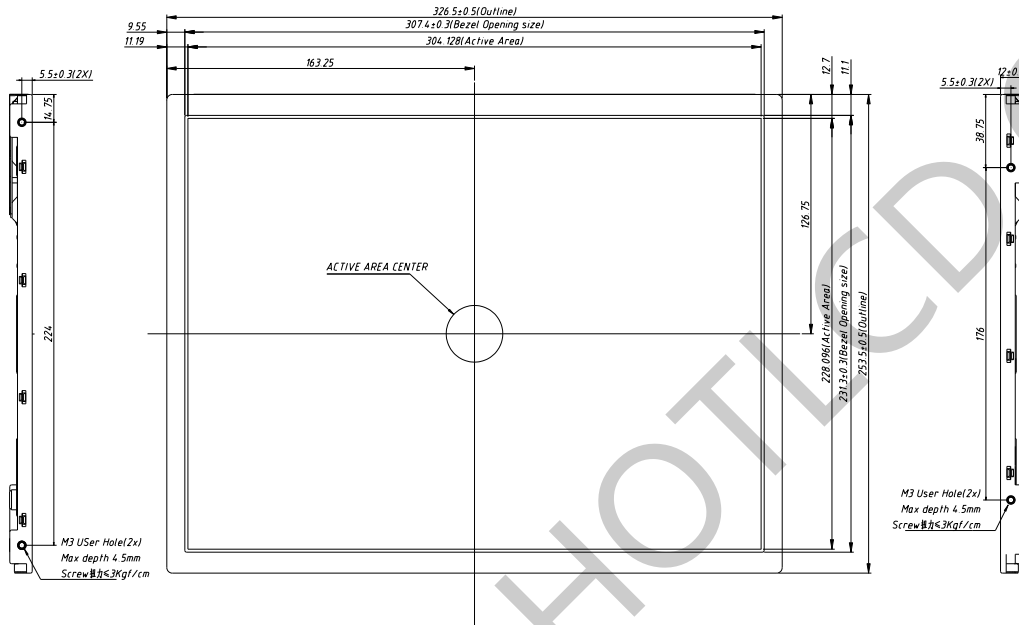

Figure 13 Reference Outline Drawing (Front Side)

HOTDISPAY

Document Title	H150GWX3 R0 Tentative Product Specification			Page No.	19/25
Document No.		Issue date	2022/11/08	Revision	00

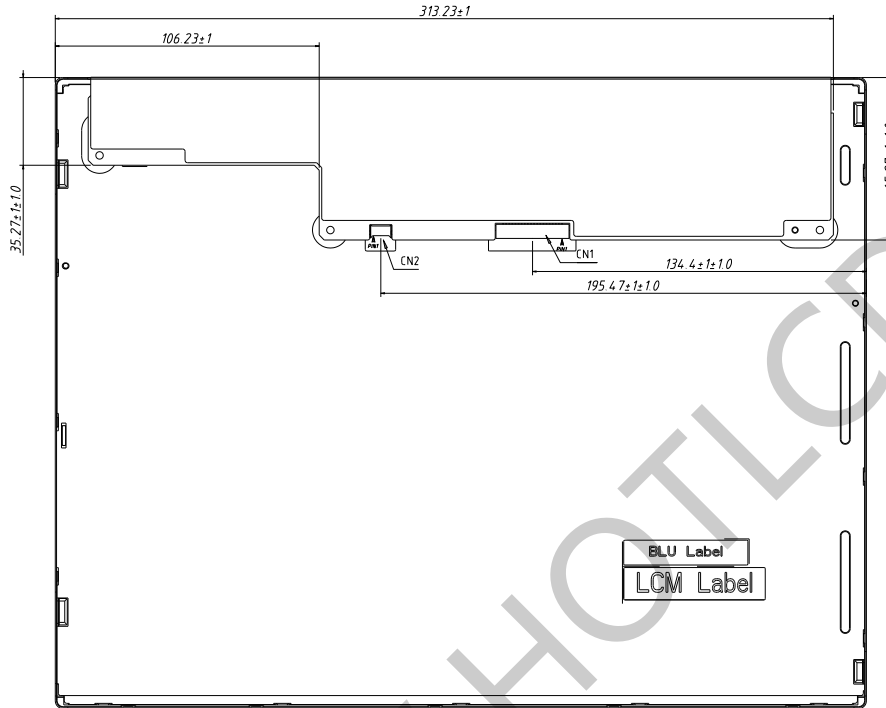

Figure 14 Reference Outline Drawing (Back Side)

Note(1): General tolerance ± 0.5

Note(2): Torque of M3 user hole should be within 3Kgf/cm and re-screw 10times

HOTDISPAY

Document Title	H150GWX3 R0 Tentative Product Specification			Page No.	20/25
Document No.		Issue date	2022/11/08	Revision	00

5.2 Dimension Specifications

Table 12 Module Dimension Specifications

Item	Min.	Typ.	Max.	Unit
Width	326.0	326.5	327.0	mm
Height	253.0	253.5	254.0	mm
Thickness	11.5	12.0	12.5	mm
Weight	-	-	1165	g

HOTDISPAY

Document Title	H150GWX3 R0 Tentative Product Specification	Page No.	21/25
Document No.	Issue date	2022/11/08	Revision
			00

6.0 Reliability Conditions

Table 13 Reliability Condition

Item	Package	Test Conditions	Note	
High Temperature Operating Test	Module	$T_{gs}=70^{\circ}\text{C}$, 300 hours	(1),(2),(3),(4)	
Low Temperature Operating Test	Module	$T_a=-20^{\circ}\text{C}$, 300 hours	(1),(2),(3),(4)	
High Temperature Storage Test	Module	$T_a=80^{\circ}\text{C}$, 300 hours	(1),(3),(4)	
Low Temperature Storage Test	Module	$T_a=-30^{\circ}\text{C}$, 300 hours	(1),(3),(4)	
High Temperature/High Humidity Operating Test	Module	$T_{gs}=50^{\circ}\text{C}$, 85%RH, 300 hours	(1),(2),(3),(4)	
Thermal Shock Non-operation Test	Module	$-20^{\circ}\text{C} \sim 60^{\circ}\text{C}$, 1hr/each cycle, 100cycles	(1),(3),(4)	
Shock Non-operating Test	Module	50G, 20ms, Half Sine Wave, ($\pm X, \pm Y, \pm Z$)	(1),(3),(5)	
Vibration Non-operating Test	Module	1.5G, 10~200 Hz, x、y、z each axis/30min		
ESD Test	Operating	Contact	$\pm 8 \text{ KV}$, 150pF(330Ohm)	(1),(2), (6)
		Air	$\pm 15 \text{ KV}$, 150pF(330Ohm)	
	Non-operating	Contact	$\pm 10 \text{ KV}$, 150pF(330Ohm)	(1),(6)
		Air	$\pm 20 \text{ KV}$, 150pF(330Ohm)	

Note (1) A sample can only have one test. Outward appearance, image quality and optical data can only be checked at normal conditions according to the IVO document before reliable test. Only check the function of the module after reliability test.

Note (2) The setting of electrical parameters should follow the typical value before reliability test.

Note (3) During the test, it is unaccepted to have condensate water remains. Besides, protect the module from static electricity.

Note (4) The sample must be released for 24 hours under normal conditions before judging.

Furthermore, all the judgment must be made under normal conditions. Normal conditions are defined as follow: Temperature: 25°C , Humidity: $55 \pm 10\% \text{RH}$. T_a = Ambient Temperature, T_{gs} = Glass Surface Temperature.

Note (5) The module should be fixed firmly in order to avoid twisting and bending.

Note (6) It could be regarded as pass, when the module recovers from function fault caused by ESD after resetting.

HOTDISPAY

Document Title	H150GWX3 R0 Tentative Product Specification			Page No.	22/25
Document No.		Issue date	2022/11/08	Revision	00

7.0 Package Specification

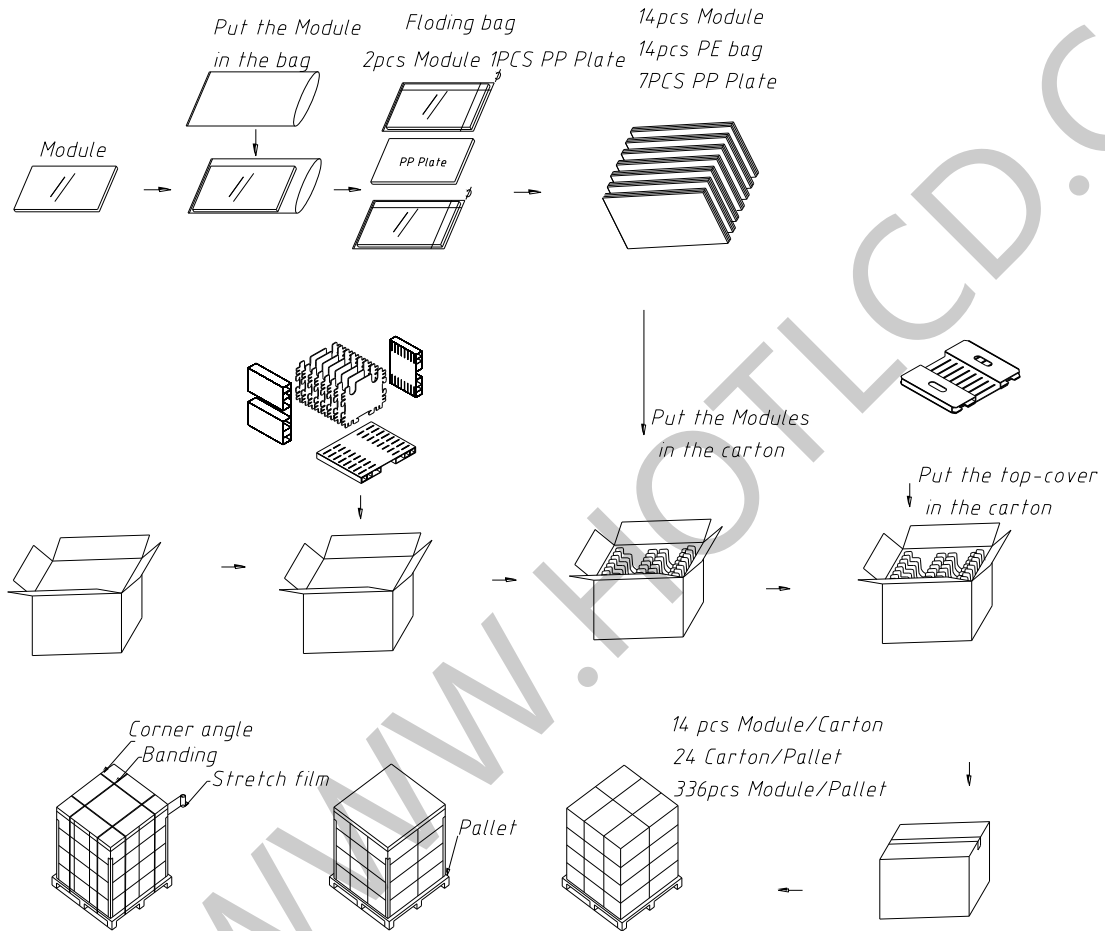

Figure 15 Packing Method

HOTDISPAY

Document Title	H150GWX3 R0 Tentative Product Specification			Page No.	23/25
Document No.		Issue date	2022/11/08	Revision	00

8.0 Lot Mark



Note: This picture is only an example.

8.1 20 Lot Mark

1	2	3	4	5	6	7	8	9	10	11	12	13	14	15	16	17	18	19	20
---	---	---	---	---	---	---	---	---	----	----	----	----	----	----	----	----	----	----	----

Code 1,2,4,5,6,7,8,9,10,11,16: IVO internal flow control code.

Code 3: Production Location.

Code 12: Production Year.

Code 13: Production Month.

Code 14,15: Production Day.

Code 17,18,19,20: Serial Number.

8.2 23 Customer Code

1	2	3	4	5	6	7	8	9	10	11	12	13	14	15	16	17	18	19	20	21	22	23
---	---	---	---	---	---	---	---	---	----	----	----	----	----	----	----	----	----	----	----	----	----	----

Code 1,2: Manufacture District.

Code 3,4,5,6,7: IVO internal module name.

Code 8,9,10,13,16: IVO internal flow control code.

Code 11,12: Cell location Suzhou, China defined as "KS".

Code 14,15: Module location Kunshan, China defined as "KS"; Yangzhou, China defined as "YZ"; Shenzhen, China defined as "SE"; Zhuhai, China defined as "ZH"; Suzhou, China defined as "SZ".

Code 17,18,19 : Year, Month, Day refer to Note(1), Note(2) and Note(3).

Note (1) Production Year

Year	2006	2007	2008	2009	2010	2011	2012	2013	2035
Mark	6	7	8	9	A	B	C	D	Z

Note (2) Production Month

Month	Jan.	Feb.	Mar.	Apr.	May.	Jun.	Jul.	Aug.	Sep.	Oct	Nov.	Dec.
Mark	1	2	3	4	5	6	7	8	9	A	B	C

Note (3) Production Day: 1~V.

Code 20~23 : Serial Number.

HOTDISPAY

Document Title	H150GWX3 R0 Tentative Product Specification			Page No.	24/25
Document No.		Issue date	2022/11/08	Revision	00

9.0 General Precaution

9.1 Using Restriction

This product is not authorized for using in life supporting systems, aircraft navigation control systems, military systems and any other appliance where performance failure could be life-threatening or lead to be catastrophic.

9.2 Operation Precaution

(1) The LCD product should be operated under normal conditions.

Normal conditions are defined as below:

Temperature: 25°C

Humidity: 55±10%

Display pattern: continually changing pattern (Not stationary)

(2) Brightness and response time depend on the temperature. (It needs more time to reach normal brightness in low temperature.)

(3) It is necessary for you to pay attention to condensation when the ambient temperature drops suddenly. Condensate water would damage the polarizer and electrical contacted parts of the module. Besides, smear or spot will remain after condensate water evaporating.

(4) If the absolute maximum rating value was exceeded, it may damage the module.

(5) Do not adjust the variable resistor located on the module.

(6) Sufficient suppression to the electromagnetic interference shall be done by system manufacturers. Grounding and shielding may be important to minimize the interference.

(7) Image sticking may occur when the module displayed the same pattern for long time.

(8) Do not connect or disconnect the module in the "power on" condition. Power supply should always be turned on/off by the "power on/off sequence"

(9) Ultra-violet ray filter is necessary for outdoor operation.

9.3 Mounting Precaution

(1) All the operators should be electrically grounded and with Ion-blown equipment turning on when mounting or handling. Dressing finger-stalls out of the gloves is important for keeping the panel clean during the incoming inspection and the process of assembly.

(2) It is unacceptable that the material of cover case contains acetic or chloric. Besides, any other material that could generate corrosive gas or cause circuit break by electro-chemical reaction is not desirable.

(3) The case on which a module is mounted should have sufficient strength so that external force is not transmitted to the module directly.

(4) It is obvious that you should adopt radiation structure to satisfy the temperature specification.

(5) It should be attached to the system tightly by using all holes for mounting, when the module is assembled. Be careful not to apply uneven force to the module, especially to the PCB on the back.

(6) A transparent protective film needs to be attached to the surface of the module.

(7) Do not press or scratch the polarizer exposed with anything harder than HB pencil lead. In

HOTDISPAY

Document Title	H150GWX3 R0 Tentative Product Specification			Page No.	25/25
Document No.		Issue date	2022/11/08	Revision	00

addition, don't touch the pin exposed with bare hands directly.

(8) Clean the polarizer gently with absorbent cotton or soft cloth when it is dirty.

(9) Wipe off saliva or water droplet as soon as possible. Otherwise, it may cause deformation and fading of color.

(10) Clean the panel gently with absorbent cotton or soft cloth when it is dirty. Ethanol(C₂H₅OH) is allowed to be used. Ketone (ex. Acetone), Toluene, Ethyl acid, Methyl chloride, etc are not allowed to be used for cleaning the panel, which might react with the polarizer to cause permanent damage.

(11) Do not disassemble or modify the module. It may damage sensitive parts in the LCD module, and cause scratches or dust remains. IVO does not warrant the module, if you disassemble or modify the module.

9.4 Handling Precaution

(1) Static electricity will generate between the film and polarizer, when the protection film is peeled off. It should be peeled off slowly and carefully by operators who are electrically grounded and with Ion-blown equipment turning on. Besides, it is recommended to peel off the film from the bonding area.

(2) The protection film is attached to the polarizer with a small amount of glue. When the module with protection film attached is stored for a long time, a little glue may remain after peeling.

(3) If the liquid crystal material leaks from the panel, keep it away from the eyes and mouth. In case of contact with hands, legs or clothes, it must be clean with soap thoroughly.

9.5 Storage Precaution

When storing modules as spares for long time, the following precautions must be executed.

(1) Store them in a dark place. Do not expose to sunlight or fluorescent light. Keep the temperature between 5°C and 35°C at normal humidity.

(2) The polarizer surface should not come in contact with any other object. It is recommended that they be stored in the container in which they were shipped.

(3) It is recommended to use it in a short-time period, after it's unpacked. Otherwise, we would not guarantee the quality.

9.6 Others

When disposing LCD module, obey the local environmental regulations.